

SA|Eng.

Soluzioni per l'Ambiente



SA2 - 1300

TWO SHAFTS SHREDDER

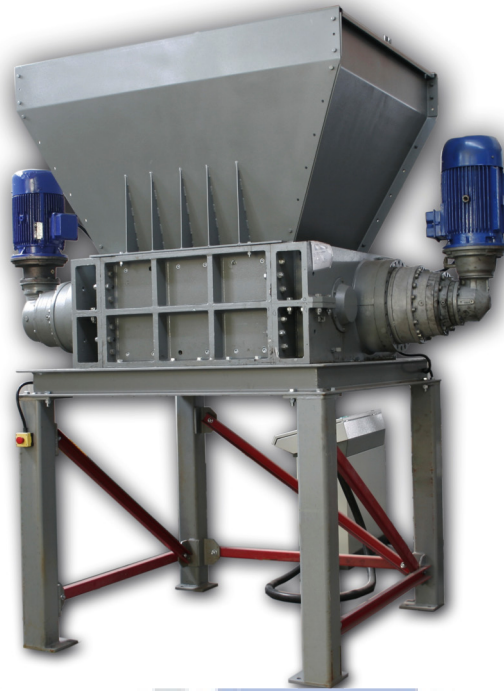

High torque machine with low speed shafts

- Shredding chamber size 1300 x 1000 mm
- Electric motor installed directly into the transmission system
- Low maintenance version with fast removal system of shafts and blades
 - Blades thickness 50 mm
- Blades available on different material variable from the shredded wastes

Ideal for the treatment of:

Plastics - Tires - Wood - Electronic waste - Municipal waste



SA2 - 1300

TWO SHAFTS SHREDDER

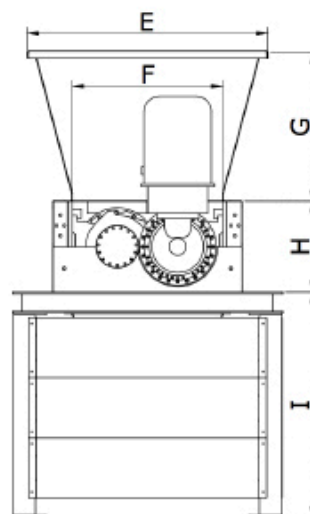
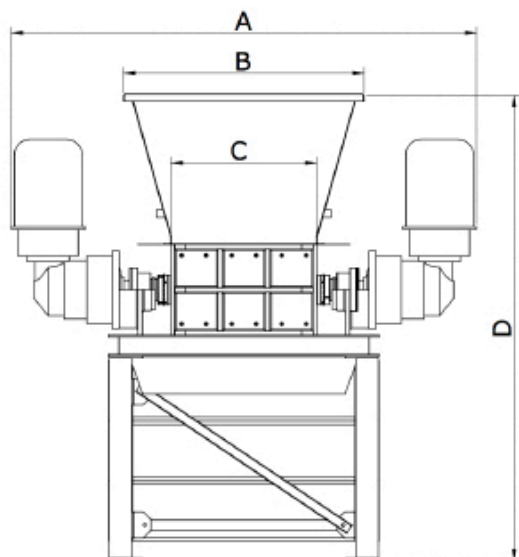

Dimensioni	
A:	3400
B:	1900
C:	1300
D:	3130
E:	1600
F:	1000
G:	1000
H:	600
I:	1500



Visit our website

You're welcome !!
Come to visit us



TECHNICAL DETAILS:

• Shredding chamber

- Chamber size	mm	1300 x 1000 x 600
- Number of shafts	n.	2
- Shafts speed	rpm	21/18
- Number of blades	n.	20
- Blades thickness	mm	50
- Kind of blades		with 1 hook
- Gearboxes	n.	2
- Trasmission system		Direct

• Drive system

- Electric motor	n.	2
- Installed power	kW	2 x 22
	HP	60
	V	400
- Control system		by PLC

• Machine weight

Kg 4500 ca.

Technical characteristics can be change without notice

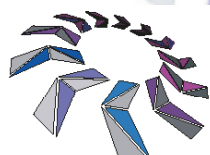

SA|Eng.
Soluzioni per l'Ambiente

Legal office and North East Italy representation: Via Noventa, 80 - San Donà di Piave (VE)
Operative office, Export and North West Italy representation: Via Della Filanda, 9 - Arluno (Mi)
Tel: +39 02 22 19 1230 www.sa-eng.it info@sa-eng.it